

APPROVAL SHEET

MULTILAYER CERAMIC ANTENNA

RFANT Series – RoHS Compliance

2.4 GHz ISM Band Working Frequency

P/N: RFANT3216120A5T Series

*Contents in this sheet are subject to change without prior notice.

FEATURES

1. Surface Mounted Devices with a small dimension of 3.2 X 1.6 X1.2 mm³ meet future miniaturization trend.
2. LTCC process
3. High stability in Temperature / Humidity Change

APPLICATIONS

1. 2.4GHz ISM band RF applications
2. Bluetooth, Wireless, HomeRF

CONSTRUCTION

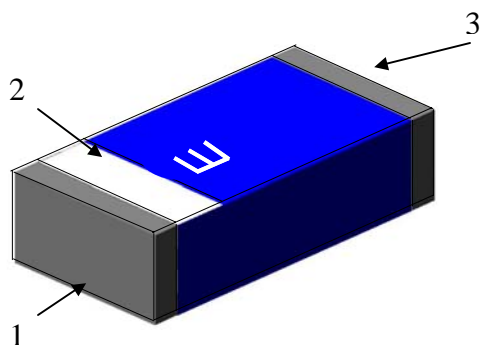

1. Feeding
2. Identification Mark
3. Soldering terminal

DIMENSIONS

Figure	Symbol	Dimension (mm)
	L	3.20 ± 0.20
	W	1.60 ± 0.10
	T	1.20 ± 0.10
	a	0.25 ± 0.15

SOLDER LAND PATTERN DESIGN

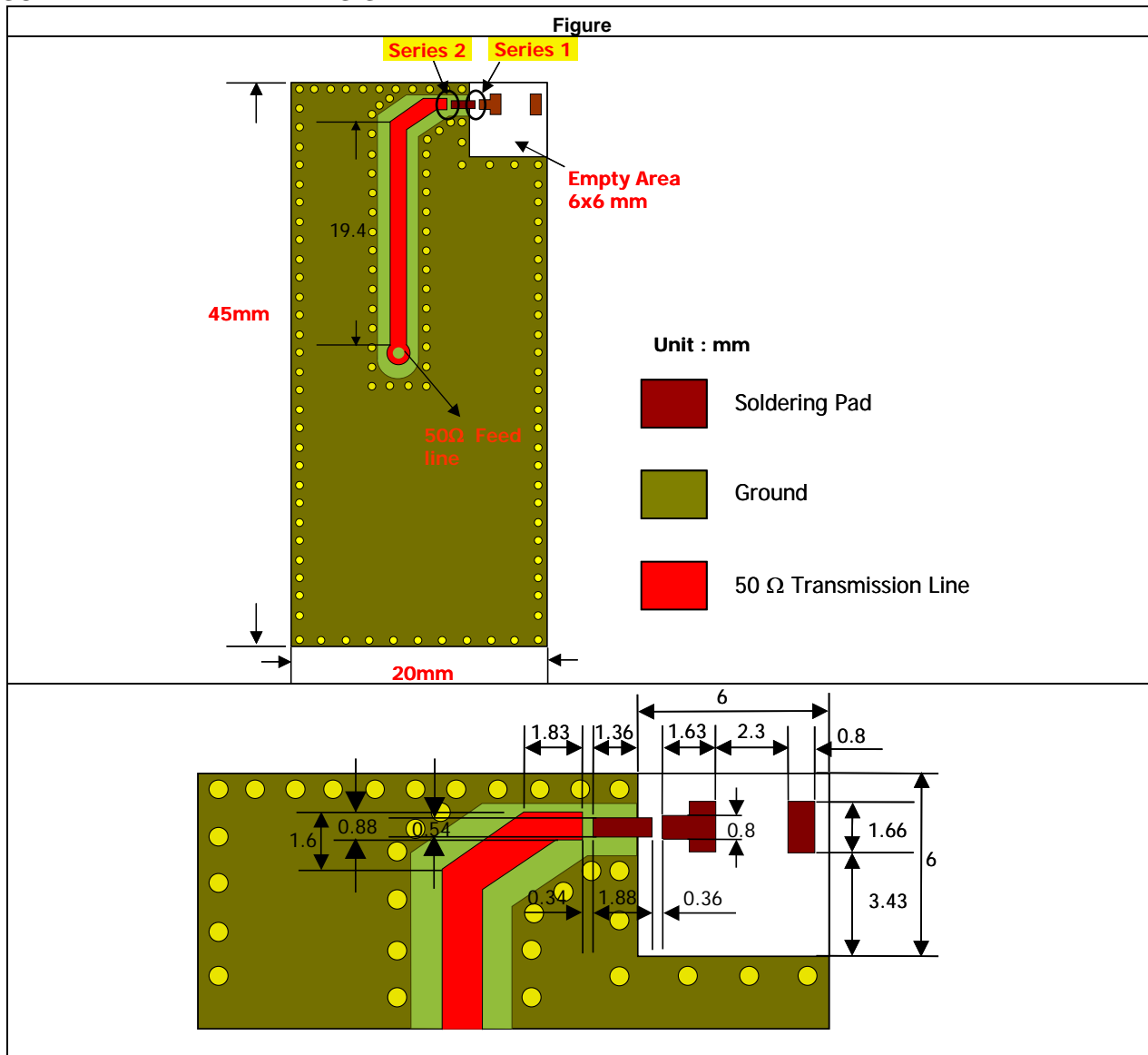

ELECTRICAL CHARACTERISTICS

Product code		Specification
Working Frequency Range		2450 ± 50 MHz
Fc (GHz)		2.9
Gain (dBi)		2 (Typical)
Matching component valve	Series 1	6.8nH
	Series 2	-

* This frequency must be adjusted to 2.45GHz with matching circuit.

Antenna on Test Board (Thickness 1.2mm)

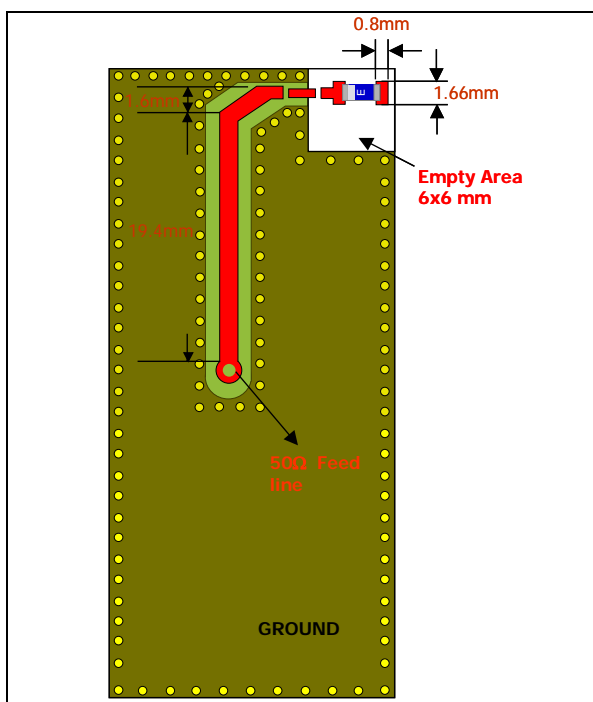

Antenna S11 on Test Board

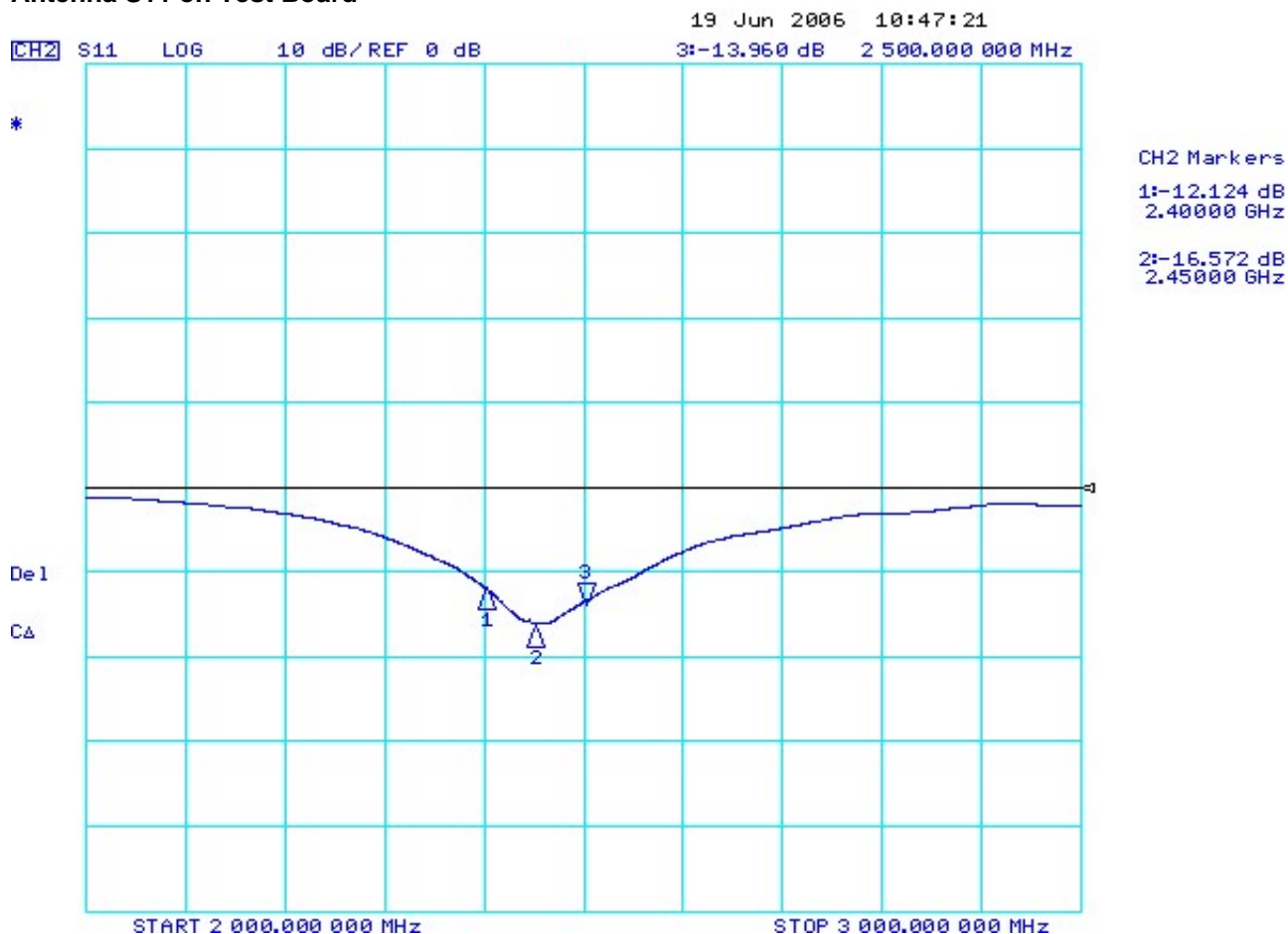

RADIATION PATTERN

Radiation Pattern and Gain were dependent on measurement board design. The specification of RFANT3216120A5T antenna was measured based on the PCB size and installation position as shown in the below figure Test Board

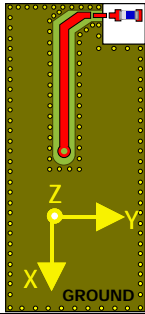

	Vertical	Horizontal
Y - Z Plane Average Gain= 0.891 dBi	<p>Peak Gain = 2.12dBi Average Gain = 0.64 dBi</p>	<p>Peak Gain= -6.07dBi Average Gain=-11.62dBi</p>
X - Z Plane Average Gain= -1.846 dBi	<p>Peak Gain= -7.78 dBi Average Gain= -11.97dBi</p>	<p>Peak Gain= 0.96 dBi Average Gain= -2.29 dBi</p>
X - Y Plane Average Gain= -2.556 dBi	<p>Peak Gain= -9.41 dBi Average Gain= -15.54dBi</p>	<p>Peak Gain= 1.40 dBi Average Gain= -2.78 dBi</p>

RELIABILITY TEST

■ Mechanical performance

Test item	Test condition / Test method	Specification
Solderability	Solder temp. : $235 \pm 5^{\circ}\text{C}$ Immersion time: 2 ± 1 sec Solder: SN63	At least 95% of a surface of each terminal electrode must be covered by fresh solder.
Resistance to soldering heat	Solder: Sn63 Preheating temperature: $150 \pm 10^{\circ}\text{C}$ Solder Temperature: $260 \pm 5^{\circ}\text{C}$ Immersion time: 10 ± 1 sec Measurement to be made after keeping at room temp. for 24 ± 2 hrs.	No mechanical damage. Ceramic surface shall not be exposed in the middle of the termination or on the terminated product edge by leaching.
Drop Test	Height : 75 cm Times : 3 times	No mechanical damage. Samples shall satisfy electrical specification after test.

■ Environmental characteristics

Test item	Test condition / Test method	Specification
Humidity (steady conditions)	Humidity: 90% to 95% R.H. Temperature: $40 \pm 2^{\circ}\text{C}$ Time: 1000 ± 24 hours. Measurement: After placing for 24 hours Minimum.	No mechanical damage. Samples shall satisfy electrical specification after test.
Temperature cycle	1. 30 ± 3 minutes at $-40^{\circ}\text{C} \pm 3^{\circ}\text{C}$, 2. 10~15 minutes at room temperature, 3. 30 ± 3 minutes at $+85^{\circ}\text{C} \pm 3^{\circ}\text{C}$, 4. 10~15 minutes at room temperature, Total 100 continuous cycles Measurement after placing for 48 ± 2 hrs min.	No mechanical damage. Samples shall satisfy electrical specification after test.
High temperature	Temperature: $85^{\circ}\text{C} \pm 2^{\circ}\text{C}$ Test duration: 1000+48/-0 hours Measurement must be taken after subjection to the above conditions, followed by exposure in room environment for 1 to 2 hours.	No mechanical damage. Samples shall satisfy electrical specification after test.
Low temperature	Temperature: $-40^{\circ}\text{C} \pm 3^{\circ}\text{C}$ Test duration: 1000+48/-0 hours Measurement must be taken after subjection to the above conditions, followed by exposure in room environment for 1 to 2 hours.	No mechanical damage. Samples shall satisfy electrical specification after test.

SOLDERING CONDITION

Typical examples of soldering processes that provide reliable joints without any damage are given in Fig 2

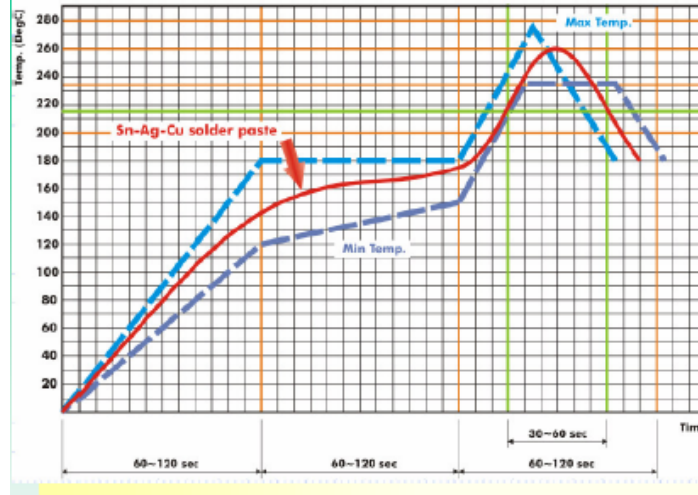
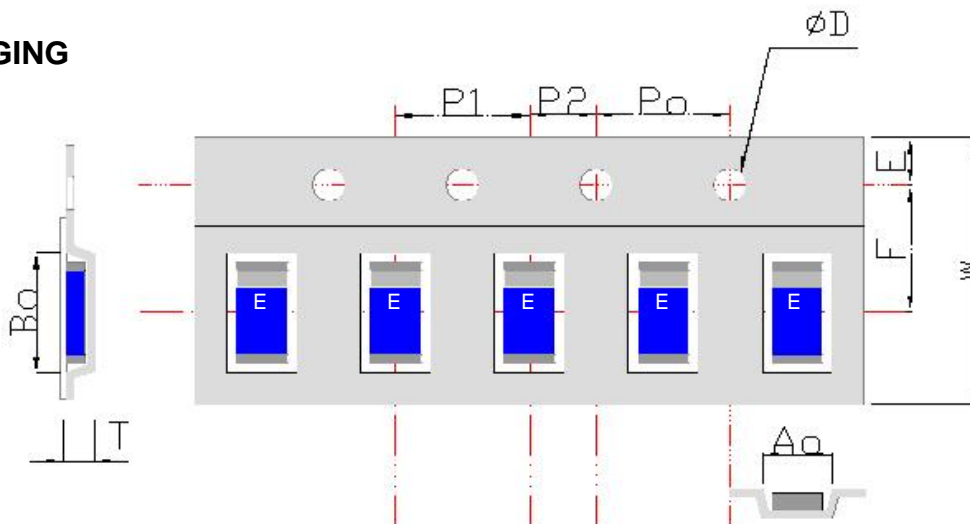

Fig 2. Infrared soldering profile

ORDERING CODE

RF	ANT	321612	0	A	5	T
Walsin RF device	Product code ANT : Antenna	Dimension code Per 2 digits of Length, Width, Thickness : e.g. : 321612 = Length 32, Width 16, Thickness 12	Unit of dimension 0 : 0.1 mm 1 : 1.0 mm	Application A : 2.4GHZ ISM Band	Specification Design Code	Packing T : 7" Reeled G : 10" Reeled B : Bulk X : SFC product

PACKAGING



Plastic Tape specifications (unit :mm)

Index	Ao	Bo	ϕD	T	W
Dimension (mm)	1.95 ± 0.10	3.45 ± 0.10	1.55 ± 0.05	1.30 ± 0.10	8.20 +0.10 -0.30
Index	E	F	Po	P1	P2
Dimension (mm)	1.75 ± 0.10	3.50 ± 0.05	4.00 ± 0.10	4.00 ± 0.10	2.00 ± 0.10

Reel dimensions

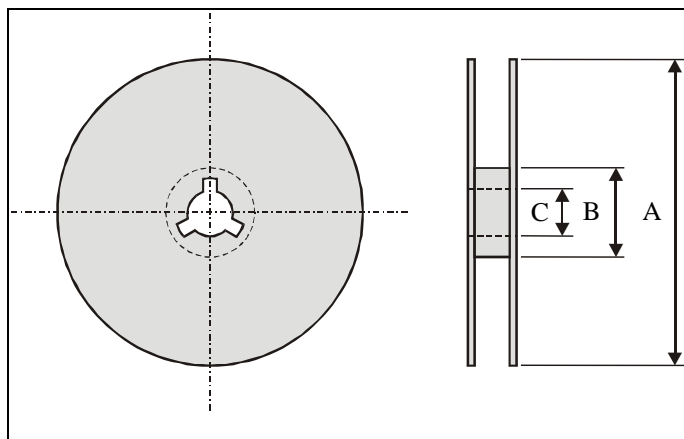

Index	A	B	C
Dimension (mm)	Φ178	Φ60.0	Φ13.5

Typing Quantity: 2000 pieces per 7" reel

CAUTION OF HANDLING

Limitation of Applications

Please contact us before using our products for the applications listed below which require especially high reliability for the prevention of defects, which might directly cause damage to the third party's life, body or property.

- (1) Aircraft equipment
- (2) Aerospace equipment
- (3) Undersea equipment
- (4) Medical equipment
- (5) Disaster prevention / crime prevention equipment
- (6) Traffic signal equipment
- (7) Transportation equipment (vehicles, trains, ships, etc.)
- (8) Applications of similar complexity and /or reliability requirements to the applications listed in the above.

Storage condition

- (1) Products should be used in 6 months from the day of WALSIN outgoing inspection, which can be confirmed.
- (2) Storage environment condition.

- Products should be storage in the warehouse on the following conditions.
- Temperature : -10 to +40°C
- Humidity : 30 to 70% relative humidity
- Don't keep products in corrosive gases such as sulfur. Chlorine gas or acid or it may cause oxidization of electrode, resulting in poor solderability.
- Products should be storage on the palette for the prevention of the influence from humidity, dust and son on.
- Products should be storage in the warehouse without heat shock, vibration, direct sunlight and so on.

Products should be storage under the airtight packaged condition.